



The Advance Xitanium SR LED driver can help reduce complexity and cost of light fixtures used in wireless connected lighting systems. It features a standard digital interface to enable direct connection to SR-certified components. Functionality that ordinarily would require additional auxiliary components is integrated into the driver. The result is a simple, cost-effective light fixture that can enable every fixture to become a wireless node.

### Specifications

Input Voltage (Vrms)	Output Power (W)	Output Voltage (V)	Output Current (A)	Efficiency@ Max. Load and 70°C Case	Max. Case Temp (°C)	Input Current (Arms)	Max. Input Power (W) <sup>1</sup>	THD @ Max. Load	Power Factor @ Max. Load	Surge Protection Common/Diff (KV)	Dim.	Dimming Range	Min. Output Current (A)	Driver Type
120	95	20-54	0.10-2.75	88	Life - 85°C UL - 90°C	0.90	118	<10%	>0.95	6	DALI	1% - 100%	0.007	Constant Current
277		Class 2 Output		90		0.39								

### Enclosure

	In. (mm)	Tolerance (mm)
Overall Length (A1)	9.43(239.5)	±0.5
Mounting Length (A2)	8.91(226.2)	±0.5
Case Length (A3)	8.39(213)	±0.5
Case Width (B1)	2.30(58.3)	±0.5
Mounting width(B2)	1.69(42.9)	±0.5
Case Height (C1)	1.48(37.6)	±1.0
Mounting Hole Diameter (D1)	0.23(5.9)	±0.5
Mounting Hole Diameter (D2)	0.31(7.9)	±0.5
Center of SimpleSet Antenna (G1)	4.41(112.1)	±3.0

### Wiring Diagram

	Wire Length (mm)
Black (Line)	270 (± 30)
White (Neutral)	270 (± 30)
Red (Positive, LED output)	270 (± 30)
Blue (Negative, LED output)	270 (± 30)
Violet/White (Positive, DA+)	270 (± 30)
Pink/White (Negative, DA-)	270 (± 30)
Brown(Positive +24V)	270 (± 30)

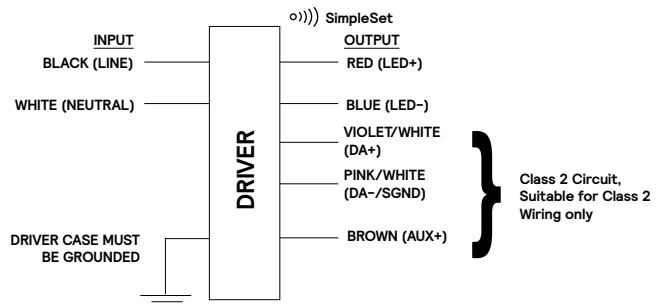

#### WARNING:

Install in accordance with national and local electrical codes

The field-wiring leads or push-in terminals shall be fully enclosed  
Les fils de câblage sur place ou les bornes enfichables doivent être entièrement fermés

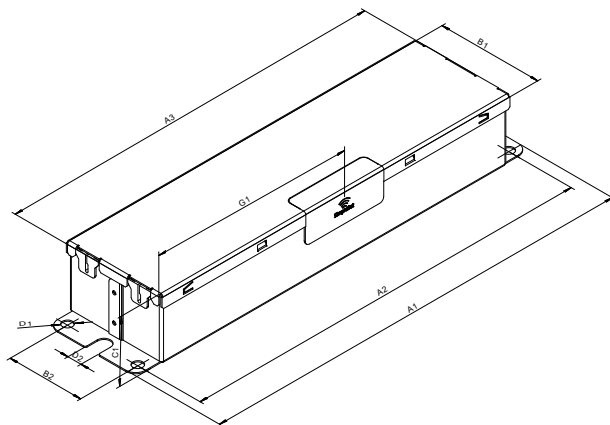

1. Based on 1W load from SR power supply and 6.2W load from auxiliary power supply.

# Xitanium SR XI095C275V054VSF2

95W 120-277V 2.75A SR D4i

## Electrical Specifications

All the specifications are typical and at 25°C Tcase unless specified otherwise.

### Features

- Standard-compliant (ANSI C137.4 and DiiA) digital interface including:
  - Integrated DALI bus power supply (Part 250)
- Memory Bank 1 extension, Energy Monitoring and Diagnostics (Parts 251, 252, 253)
- 24V Auxiliary power supply for higher power device requirements (Part 150)
- Accurate energy metering
- Drive current setting via SimpleSet (wireless)
- 5-year limited warranty<sup>1</sup>

### Benefits

- Enables interoperability with compatible third-party networked lighting control (NLC) solutions
- Reduces cost and complexity of outdoor connected lighting systems<sup>2</sup>
- Standardized luminaire data for Asset Management
- 4% metering accuracy meets proposed ANSI standard C136.52

### Application

- Area
- Industrial high-bay
- Parking garages
- Floodlights

## Product Data

Ordering Information	
Order Code	XI095C275V054VSF2M (Mid-Pack, 10pcs/Box), 12NC: 929002746313
Global Trade Identification Number (GTIN)	781087169117
Input Information	
Line Frequency	50/60Hz
Min. Mains Voltage Operational	108Vac
Max. Mains Voltage Operational	305Vac
Output Information	
Output Voltage Range	20VDC to 54VDC
Output Current Range	0.10A to 2.75A
Output Current Ripple	<15% at max. lout (ripple = pk-avg/avg) Low frequency (<120 Hz) content <1%
Flicker	Meets NEMA 77
Output Current Tolerance	±5% at max. output current
Open Circuit Voltage	54VDC
Protections	Short Circuit and Open Circuit Protection for LED + and LED- and Thermal foldback protection
Control Lead Current Leakage (SR)	0.01mA, recommended max number of control circuits in parallel refer to Design-In Guide
Standby power@ 277vin	<0.5W <sup>3</sup>
Features	
AOC (adjustable output current)	0.10A to 2.75A via SimpleSet programming (refer to graphs and notes)
Life	50,000 hr nom. @ TC 85°C; 100,000 hr nom. @ TC 75°C (refer to graphs)
Suitable for Outdoor Use?	Yes
Interfaces	SimpleSet, Sensor Ready (SR), Auxiliary Power Supply
Power Reporting Accuracy	+/- 4% in performance window and under nominal operating conditions
Configurable Features	Advance Driver Thermal Limit, Dynadimmer, Password protection, and many others.

1. Advance Xitanium LED drivers are designed and manufactured to engineering standards correlating to an average life expectancy of 50,000 hours of operation at maximum rated case temperature. Minimum 90% survivals based on MTF modeling.

2. Functionality that ordinarily would require additional auxiliary components is integrated into the driver.

3. With No loading on control terminals and SR disabled.

# Xitanium SR XI095C275V054VSF2

95W 120-277V 2.75A SR D4i

## Electrical Specifications

All the specifications are typical and at 25°C Tcase unless specified otherwise.

## Product Data (continued)

<b>Auxiliary Power Supply (According to ANSI C137.4)</b>	
Nominal Aux. Output Voltage	24Vdc
Rated Aux. Output Power	3W continuous, 6W peak
Protections	Short Circuit & Open Circuit Protection for Aux. + and Aux. -
<b>SR power supply</b>	
Current Source	52mA to 60mA
Voltage Range	12V to 20V
Communication Protocol	DALI-2, D4i, ANSI C137.4
Mis-wiring to Mains Protection	No
<b>Environment &amp; Approbation</b>	
Min. Ambient Temp	-40°C
Earth Leakage Current	0.75 mA [max.]
Operating Ambient Temp. Range	-40C to +55C
Max Case Temperature (Tcase)	85C for Life & 90C for UL Safety
Agency Approbations	UL, CUL, NOM, FCC, Class P (UL, CUL)
Audible Noise	<24dB Class A
EMC (electromagnetic compliance)	FCC 47 Part 15 Class A
Envir. Protection Rating	UL Dry & Damp, Type HL
Net Weight Per Piece	2.02lbs / 0.92kgs

# Xitanium SR XI095C275V054VSF2

95W 120-277V 2.75A SR D4i

## Electrical Specifications

All specifications are typical and at 25°C Tcase unless specified otherwise.

## Dimming Characteristics

SR drivers use a logarithmic dimming curve as default. Dimming is accomplished through the 2-wire DALI connection to the sensor. DALI standard IEC62386\_102 Edition 2 defines the logarithmic dimming curve. DALI standard IEC62386\_101 Edition 2 defines the linear dimming curve as well as the command for switching between logarithmic and linear curves.

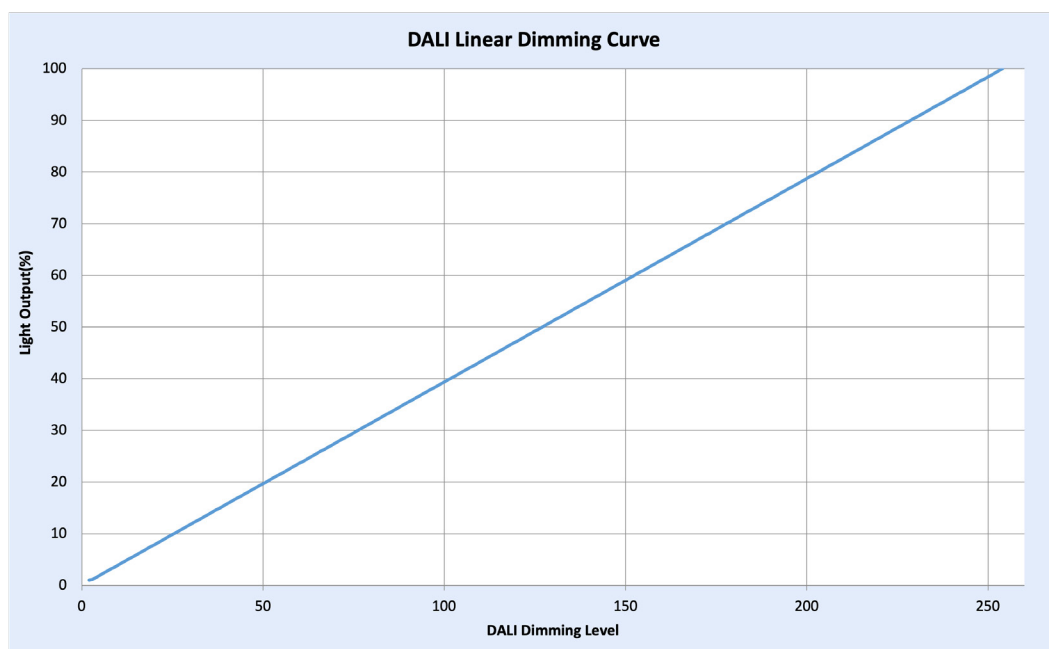
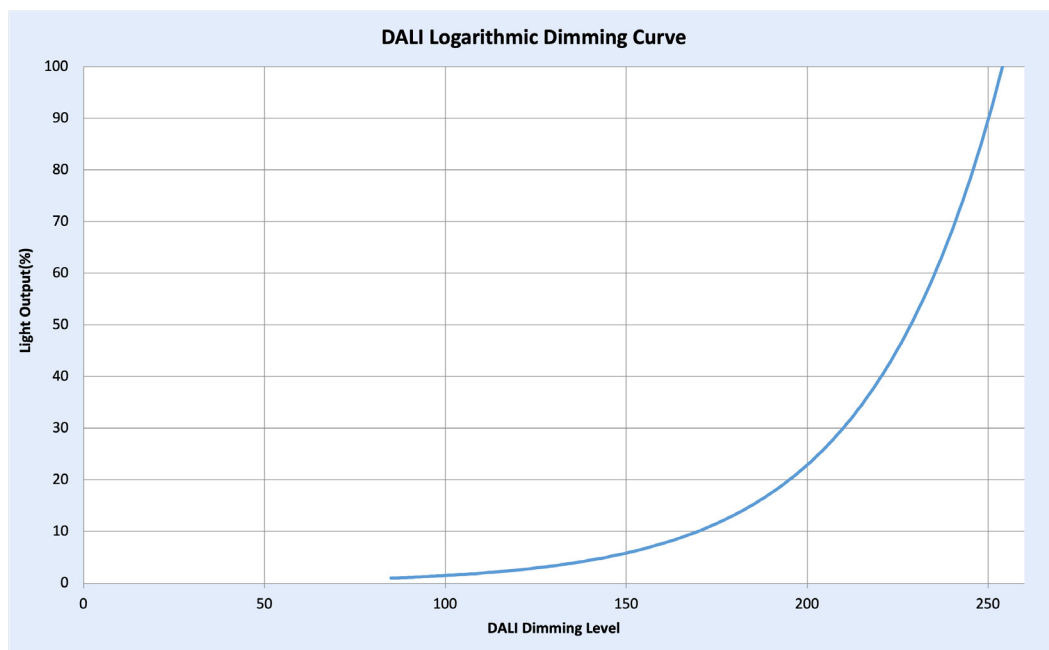

# Xitanium SR XI095C275V054VSF2

95W 120-277V 2.75A SR D4i

## Electrical Specifications

All specifications are typical and at 25°C Tcase unless specified otherwise.

## Operating Window

The driver current cutback feature provides for an increased output voltage with a reduced output current during abnormal LED operation, such as cold weather starting. Output tolerance +/-5%.

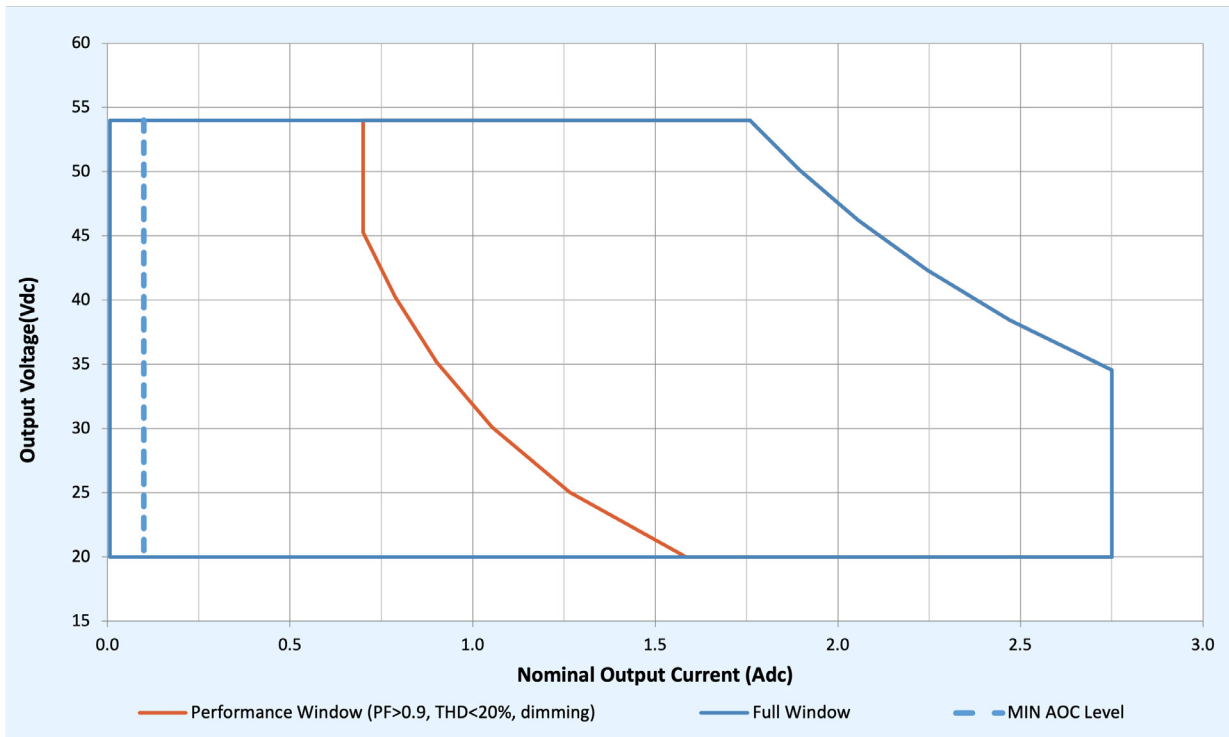

1. Factory default output current is 2.3A
2. To get a 100% to 1% dimming range, the output current setting through AOC should be  $\geq 0.7A$ .

# Xitanium SR XI095C275V054VSF2

95W 120-277V 2.75A SR D4i

## Electrical Specifications

All specifications are typical and at 25°C Tcase unless specified otherwise.

## Driver Lifetime Vs. Driver Case Temperature

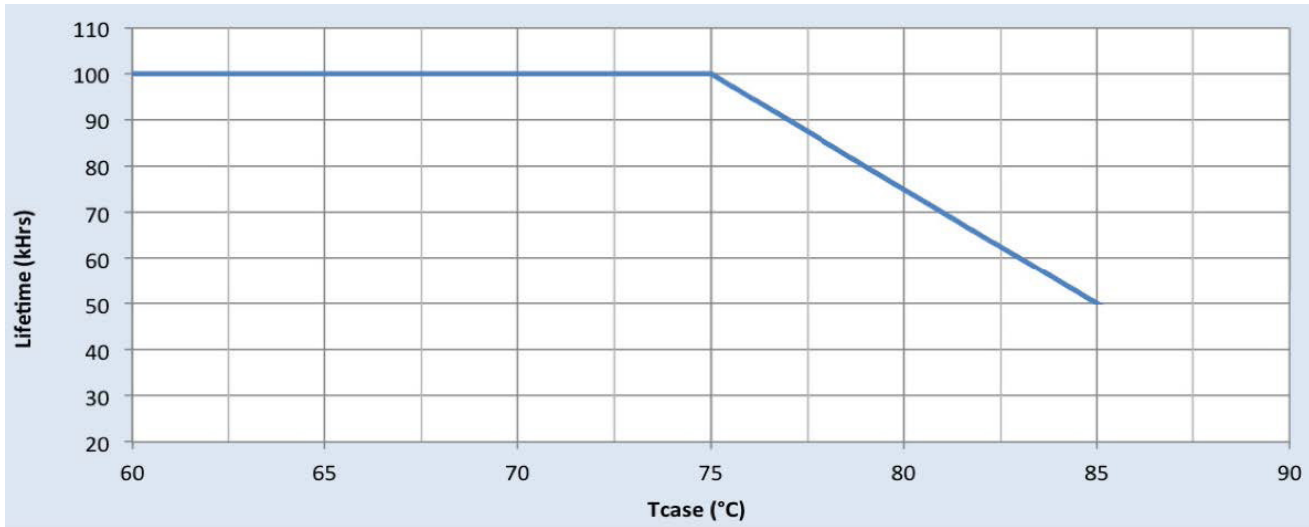

# Xitanium SR XI095C275V054VSF2

95W 120-277V 2.75A SR D4i

## Performance Characteristics

Based on measurements on a typical sample. The accuracy of the measurements is within the tolerance of the measurement instruments. The graphs are meant to be a guideline and not a specification. Data below at 70°C Tcase.

### Efficiency Vs. Output Voltage @ 120VAC

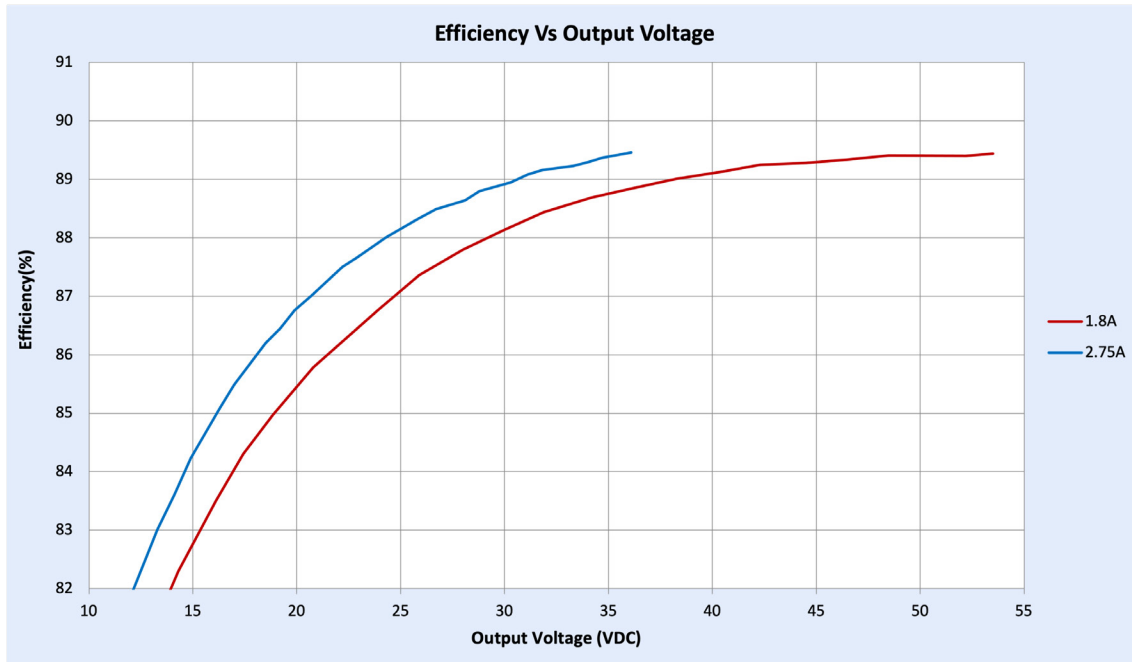

### Efficiency Vs. Output Voltage @ 277VAC

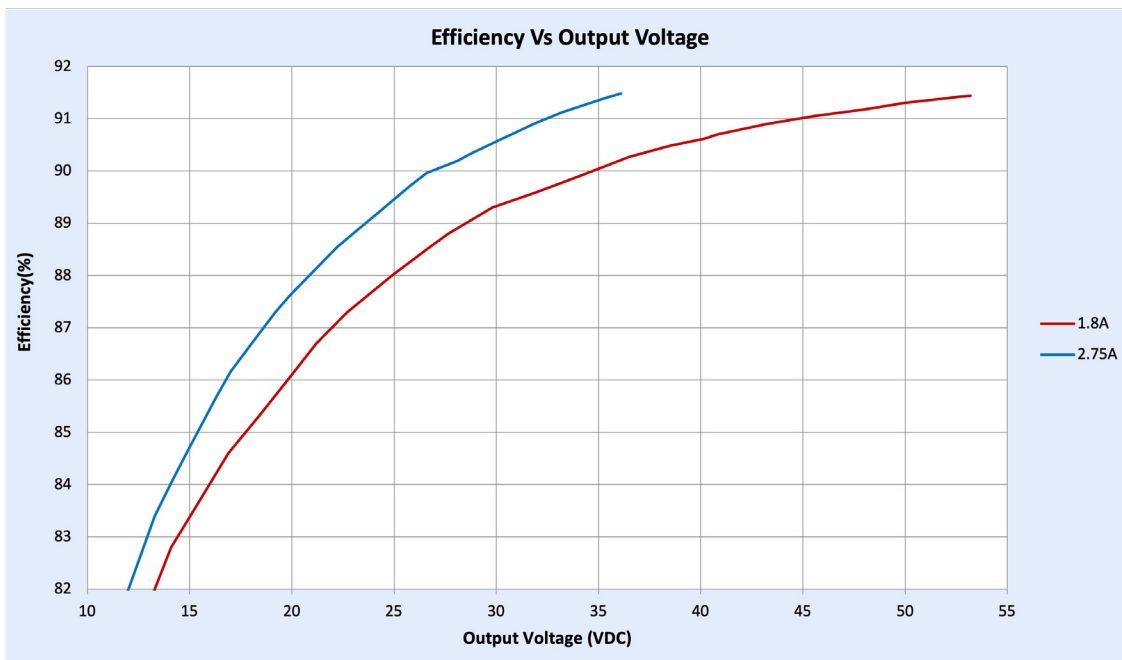

# Xitanium SR XI095C275V054VSF2

95W 120-277V 2.75A SR D4i

## Performance Characteristics

Based on measurements on a typical sample. The accuracy of the measurements is within the tolerance of the measurement instruments. The graphs are meant to be a guideline and not a specification. Data below at 70°C Tcase.

### Power Factor Vs. Output Power

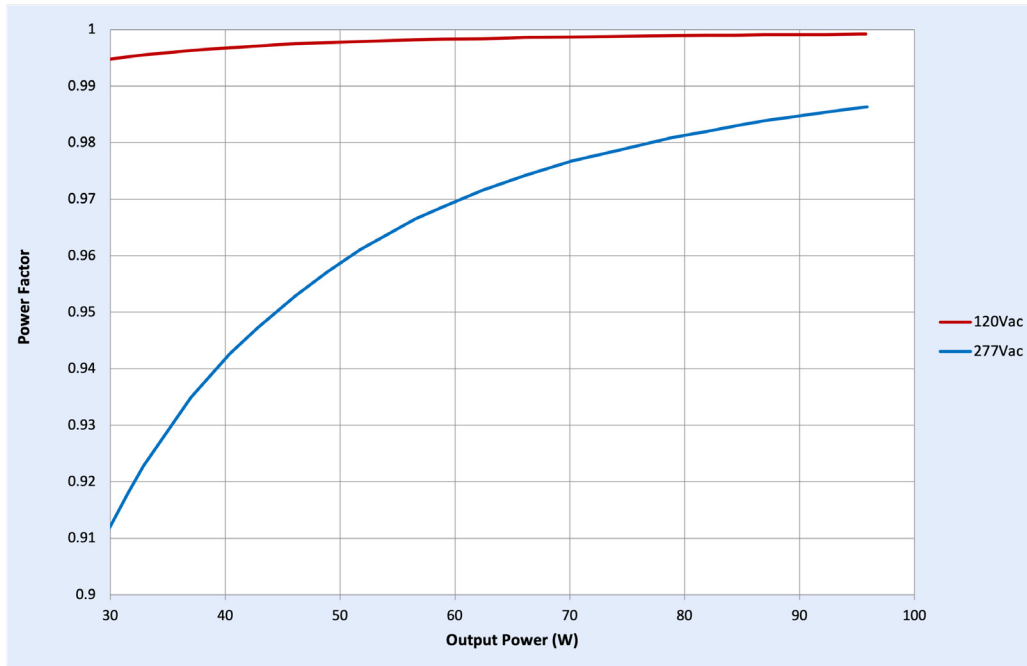

### Total Harmonic Distortion Vs. Output Power

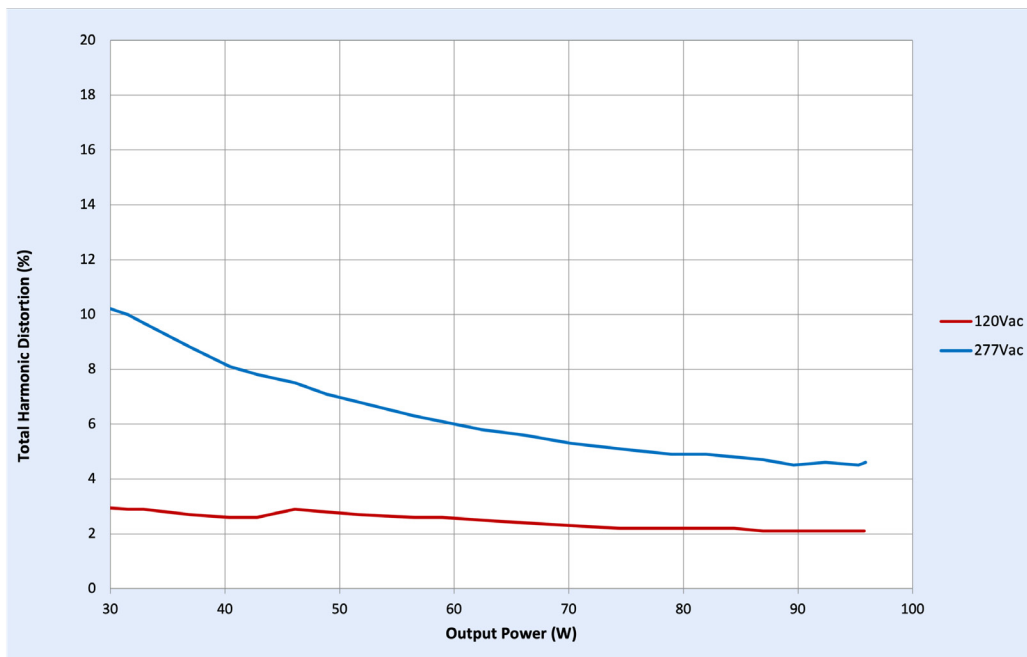

Total Harmonic Distortion content is in compliance with ANSI C82.77-10 standard



# Xitanium SR XI095C275V054VSF2

95W 120-277V 2.75A SR D4i

## Inrush Current Info

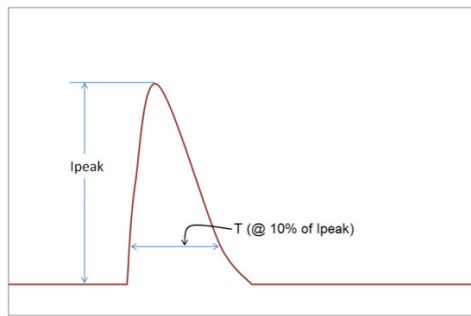

$V_{in}$	$I_{peak}$	$T$ (@ 10% of $I_{peak}$ )
120 Vac	27.4A	236 $\mu$ sec
277 Vac	65.4A	234 $\mu$ sec

Inrush current is measured at peak of the corresponding line voltage, source impedance per NEMA 410.

## Lightning Surge Info

ANSI Surge Type	Differential Mode (L-N)	Common Mode (L-G, N-G, L&N-G)
1.2/50 $\mu$ s Combination Wave (w/t 2 $\Omega$ )	6kV	6kV

## Isolation

Isolation	Input Leads	Output Leads	DALI Leads (DA+, DA-/ SGND, and AUX). Class 2 Only	Enclosure
Input Leads	NA	2xU+1kV	2xU+1kV	2xU+1kV
Output Leads	2xU+1kV	NA	500Vrms	500Vrms
DALI Leads (DA+, DA-/ SGND, and AUX). Class 2 only	2xU+1kV	500Vrms	NA	500Vrms
Enclosure	2xU+1kV	500Vrms	500Vrms	NA

U = Max. input voltage



© 2022 Signify Holding. All rights reserved. The information provided herein is subject to change, without notice. Signify does not give any representation or warranty as to the accuracy or completeness of the information included herein and shall not be liable for any action in reliance thereon. The information presented in this document is not intended as any commercial offer and does not form part of any quotation or contract, unless otherwise agreed by Signify.

Signify North America Corporation  
400 Crossing Blvd, Suite 600  
Bridgewater, NJ 08807  
Telephone: 855-486-2216

Signify Canada Ltd.  
281 Hillmount Road,  
Markham, ON, Canada L6C 2S3  
Telephone: 800-668-9008

All trademarks are owned by Signify Holding or their respective owners.